

Assembly Instructions
Basic Folding-Leg Box Frame Style

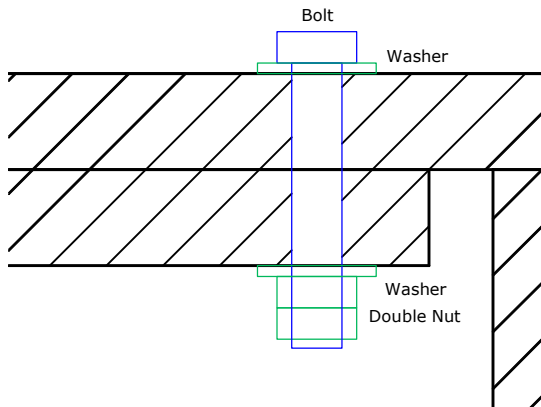

Basic Folding Leg Cornhole Board Concept

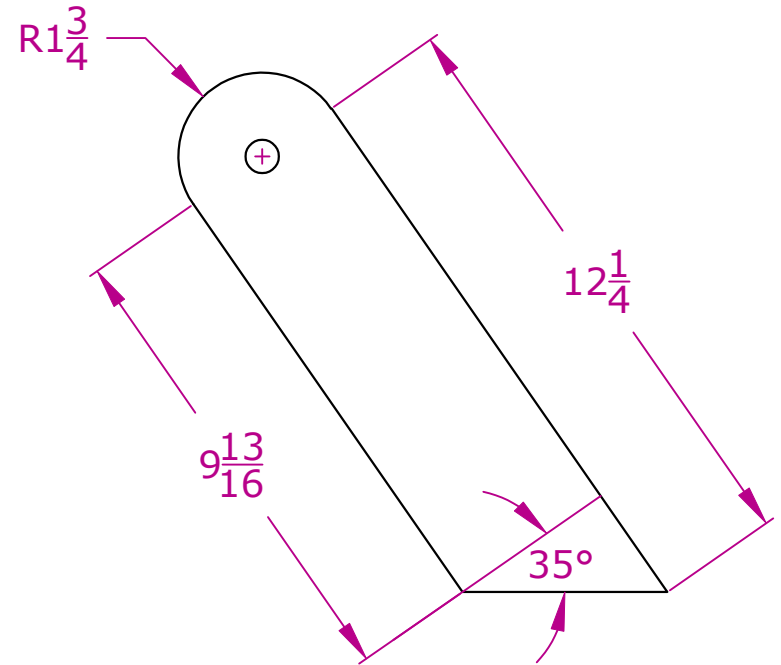

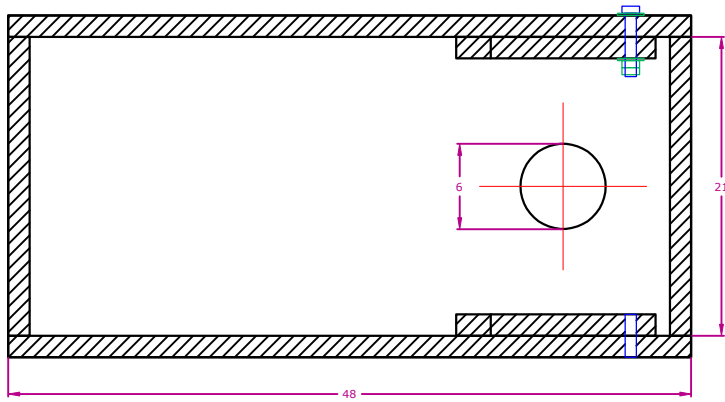
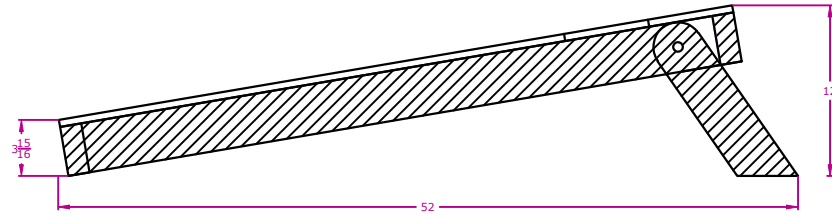
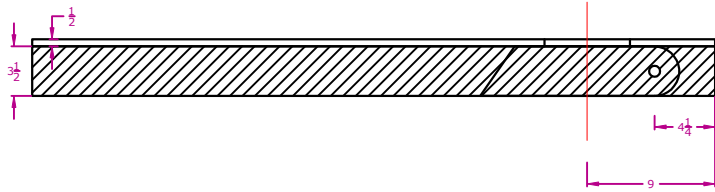



CornholePlayers.net
Jackson Van Buren

Materials

Lumber

- (4) 8' length structural 2×4s
- (2) 24"×48" sheets $\frac{1}{2}$ in plywood

Hardware

- (4) 4" long $\frac{3}{8}$ " carriage bolts 
- (4) $\frac{3}{8}$ " fender washers 
- (8) $\frac{3}{8}$ " locknuts 
- (56) 3" deck screws 

Tools (recommended)

Power Drill

Miter Saw

Belt Sander

Plunge Router or 6 in
Hole Saw

Wood Glue

Measuring Tape

Radial Arm Saw

Clamps

Drill Bits (philips, pilot,
and 3/8 in)

Orbital Sander

Step 1 – Prepare the lumber*

Cutting templates (**A** and **B**) are given as visual reference for 8 ft section cuts Cut 2 sections as given in **A** and 2 as given in **B**. When all the cuts have been made, you should have 4 *Long Side* and 4 *Short Side* segments, 4 *Legs*, and 2 *Cross Beams*.

Select one of the 8 ft of sections. Use cutting template **A** for reference. Make a cross cut **48 in** from the butt of the board. This segment will be the *Long Side* of the box frame. Then make another cross cut at **21 in**. This segment will be the *Short Side* of the box

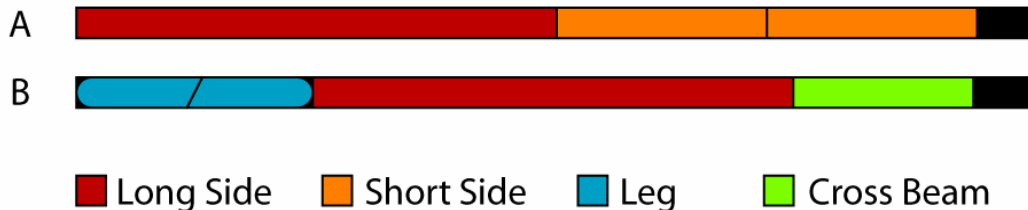

frame. Use these **48 in** and **21 in** segments as templates for making similar cuts. Cut another **21 in** segment. Discard the approximate 6 in scrap.

* See *Notes* section about *Cross Beam* alternative dimensions

Repeat with another 8 ft section, using your *Long Side* and *Short Side* segments as cutting guides.

Now implement cutting template **B**. Set the miter to 35°. Select another 8 ft section and make the following cut as shown. With the miter saw still set at 35° make the same cut on the last remaining 8 ft section. These segments will be the *Legs*. Now reset the miter angle to perpendicular.

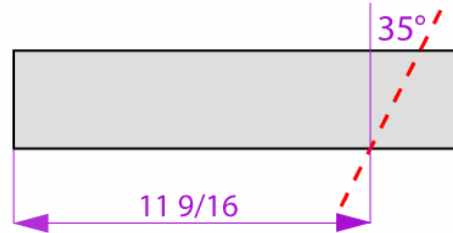

Use a *Leg* segment you've already cut as a guide by flipping it, stacking on top and lining up the mitered edge with the mitered edge of the lumber. Crosscut the lumber at the *Leg* segment butt end. Now cut a **48 in** segment. Then cut an **18 in** segment. This last segment will be the *Cross Beam*. Discard the approximate scrap.

Repeat on the last remaining section of lumber, using guides as helpful.

Step 2 – Construct the Box

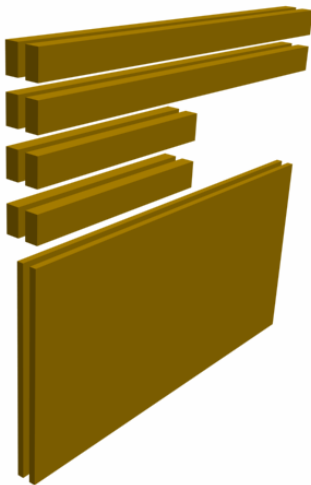

Gather the **48 in** and **21 in** segments and plywood sheets. If framing or box clamps are available to you, now would be a good time to grab them. Mock up or “dry fit” the pieces together on level ground. The longer segments should sandwich the shorter ones between them.

To ensure the box frame is square and you don't have access to framing clamps or a corner jig or anything of that nature, you can do this: Measure the diagonals and adjust the pieces until that measurement is the same. (eg $ab = cd$)

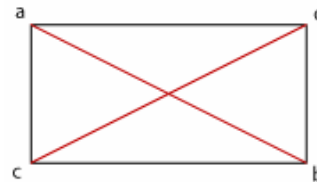

When you are satisfied with your mock up, drill pilot holes through the corners for your 3 in deck screws. Drill 2 pilots per corner on center with the backing **21 in** piece. Then proceed with wood glue and the screws. Periodically check to make sure your frames are square. Sink the screws to at least flush with the board face.

Place the sheet of plywood over the box frame and adjust its position so that full coverage of the box frame is achieved. Don't be concerned if the plywood overhangs the frame, however. That will be sanded down at a later time.

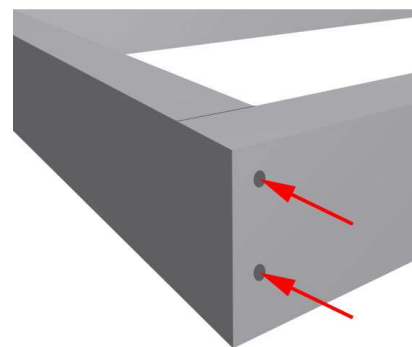

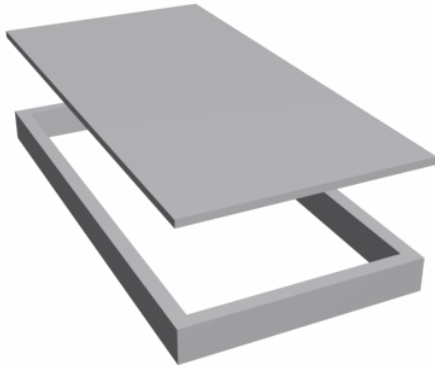

Drill pilots through the plywood into the box frame about every **6 in.** Placement will matter for aesthetic reasons if you are not planning on painting eventually. Also make sure not to drill into the horizontal screws holding the box frame together.

Remove the plywood taking care to note its orientation. Apply a bead of wood glue and replace the plywood right back where it was. Use your pilot holes for reference. Start shooting

screws working your way around the board. At this point, go back and make sure all the heads of your deck screws are sunk at least flush with the surface. If you plan on puttying, sink them below the surface.

Repeat for the other box assembly.

Once the glue has dried (and the putty if you've applied it,) use a belt sander with a heavy grit to take down any imperfections in the plywood and box frame marriage. Then finish-sand the boards with an orbital sander to take out any blemishes.

Step 3 – Cut the Hole

There are a lot of ways to do this. For all of which however, you'll have find the center first. ACA specifies that hole should measure 6 in in diameter, centered at a point 9 in from the trailing edge aligned to the middle of the board. So make a mark here on both boards. To cut the hole, I'll touch on two methods:

A. 6 inch Hole Saw

This definitely the easier of the two. Hole saws are expensive but if you can borrow one, I would strongly recommend you use this method. All you have to do is put a 6 in hole saw bit on the mandrel and drill into your center mark with through they plywood.

B. Circle Jig

You can use a router, a spiral saw (often called a roto-zip), or even a Dremel tool with this method. NOT JIGSAWS though, -the cutting blade has to be radially symmetric.

The concept here is simple; it works just like a compass. First make yourself a jig similar to the one shown. You can do this with a paint stick and nail at the pin. Make the distance between the pin center and the outer edge of the cutting blade 3 in. Drill a pivot point into the center mark on the board and a starter hole on the circumference of the circle (anywhere



3 inches away from the center mark.) Then set up your jig on the boards, turn on your tool, and rotate around the center mark until you've cut out a circle.

Note: Spiral saw bits break very easily. Save yourself an unnecessary trip to the hardware store by cutting slowly and backing out frequently.

To clean up your cuts, make yourself a contour sander out of sandpaper and a spray paint can. Then hand sand the holes to your liking.

Step 4 – Make the legs

Return now to *Leg* segments you cut in step 1. The primary design that we've been following thus far, utilizes circular filets at the pivot points[†]. To create those filets, use the circle jig method outlined in step 3. The radius you should set the jig to is one half the width of the *Leg* (**1.75 in.**) The center is at a point **1.75 in** from the butt end and an equidistant **1.75 in** from both sides. **MARK THIS CENTER WHEATHER OR NOT YOU ARE ROUNDING YOUR LEGS.**



Granted the circular pivots are structurally and aesthetically beneficial, but they do take a certain degree of craftsmanship to achieve. Fortunately, any contour will also work so long as the cut-lines are inside of a bounding radius of 1.75 in. A common alternative to circular legs, are notched ones. One can simply notch the legs by cutting 2 opposing 45° miters and then taking down the point with a cross cut or sanding.

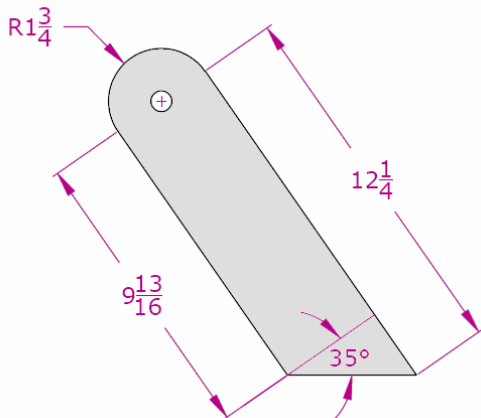

Whatever method you choose, all of your *Legs* should be uniform. A convenient way to ensure that is to clamp them all together and sand them flush.

Lastly, bore out a hole for the bolt through the center mark you made earlier. Use a **3/8 in** bit. Use an awl or drill starter hole so that the bit doesn't wander. It is crucial that the direction of the bore be as close to normal to leg face as possible. (STRAIGHT down.) If you have a drill press or a perpendicular guide, use it.

Repeat for each *Leg*.

[†] To find out why, read the *Notes* section.

Step 5 – Attach the legs to the Boards

Flip your boards so that the open box is facing up. Measure **4 1/4 in** from the edge of the board and clearly mark a line as shown in the image below. Place one of your finished

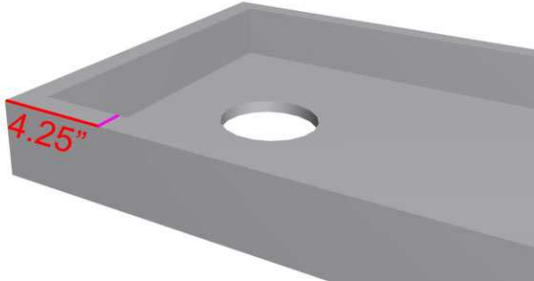

legs with the shorter end facing down into the box so that it is flush with the back of the plywood and lapped against the long side of the box. Slide the leg along until the center of the hole in the leg is in line with the mark you made on the board. Clamp the leg segment in place bore a 3/8 in hole into the box frame using the leg center hole as a guide.

Repeat for each leg in each corner.

Now assemble the folding legs to the box using a carriage bolt, a washer, and 2 locknuts per leg as shown below. Tighten the nut closest to the washer to cinch the carriage bolt head flush to the outer surface. Then loosen according to how much friction you'd like in the pivot. Then tighten the outer nut to lock everything in place.

Do that for each leg.

The boards are now completely assembled from a structural standpoint. If you choose, you can employ any of the optional steps mentioned in the *Notes* section or you can just add bags and start playing!

Many Cornhole enthusiasts, however, would move on to finishing steps. This can be anything from staining to painting to applying decals... Whatever it may be, further instruction would be beyond the scope of these instructions.

Once your happy with your boards though, there is one last thing you can do, -regardless of whether or not you've followed these particular instructions. The problematic issue of visibility as the daylight dissipates can be solved with the inclusion a Bag-o-Lantern kit. These devices emit light via a ring of 8 high brightness LED lamps arranged radially about a mounting bracket. Installation and additional info is provided on the following page.

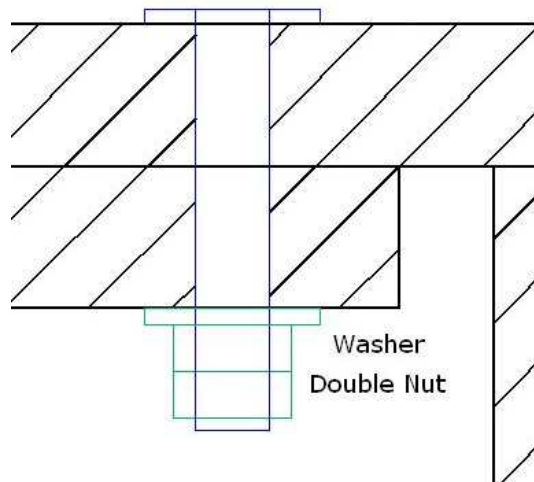

Step 6 – Bag-o-Lantern Installation

The Bag-o-Lanterns (available through www.bag-o-lantern.com) are designed to be flush-mounted from the interior of the boards. Three mounting screws for the lamp housing and two for the 9-volt battery enclosure are provided for each lantern with the kit. This addition to your boards will take only as much time as it takes you to shoot 12 screws and provide roughly 8 hours per battery of after dark play.

Install the Bag-o-Lanterns as per the manufacturer's instructions. The placement of the battery enclosure is arbitrarily, but make sure you put it in an accessible spot so that when you need to turn them on, the boards don't need to be disturbed.



When you're finished, the lanterns should look a little something like this:



That's it. Happy Cornholing!

Notes:

The *Cross Beam* (as dimensioned here) is an optional component. It gets sandwiched between the folding legs so that they fold as one. This feature is not uncommon. Generally it is held in with 4 screws, 2 shot though each leg. It poses a problem when you're not playing on flat ground though. Bascially it will lean or or one side will not touch the ground. The boards will be more rigid in the axis perpendicular to the direction you'd normally be throwing at them but you'd lose that independent suspension that separate legs have.

One could also choose to use the *Cross Beams* segments for additional box frame rigidity. The box frame would look like a boxed H frame. All you'd have to do, is substitute *Short Side* dimensions for every mention of *Cross Beam* in Step 1. This would probably cut down further on bounce and add a little more weight.

Circular filets on the leg pivots do one thing that filets of any other geometry can't. That is adding another point of contact for impact to be translated to the ground. With notched legs, all the impact energy associated with a bag toss (or whatever you're throwing at your boards) will be absorbed and concentrated into shear stress in the bolts. The circular filets actully are tangent to the back of the board surface so that impact can be directly translated through the leg member into the ground.

General Design Notes:

Why did I call for 2 separate sheets of plywood instead of one 4'by8'? So anyone can fit them into their car (myself included.) Get the 4by8 cut at the store if they don't stock it.

Why 3/8 inch hardware? Bigger (at least 1/2 inch) is better –within reason of course. The thing is that chucks on most average consumer level drills can't take a bit that big. If you've got a set of spade bits or a good drill however, I'd bump it up a notch. With spade bits you just have to be extra careful to drill perfectly straight in or your hardware have a significant amount of play.
